

MODEL T48 - 1/16 DIN TEMPERATURE CONTROLLER

- PID CONTROL WITH REDUCED OVERSHOOT
- ON DEMAND AUTO-TUNING OF PID CONTROL SETTINGS
- NEMA 4X/IP65 BEZEL
- DUAL LED DISPLAYS FOR SIMULTANEOUS INDICATION OF TEMPERATURE AND SETPOINT
- STATUS INDICATORS FOR OUTPUTS AND CONTROL MODES
- ACCEPTS 10 TYPES OF SENSOR INPUTS (Thermocouple or RTD)
- OPTIONAL HEATER CURRENT MONITOR AND HEATER BREAK ALARM
- OPTIONAL DUAL ALARM OUTPUTS
- OPTIONAL TWO LINEAR DC OUTPUTS (0 to 10 V, 0/4 to 20 mA)
- MANUAL/AUTOMATIC CONTROL MODES
- SETPOINT RAMPING FOR PROCESS STARTUP
- PROGRAMMABLE USER INPUT (Digital) FOR ADDED FLEXIBILITY
- SENSOR ERROR COMPENSATION (Offset) AND BREAK DETECTION
- HEATING AND OPTIONAL COOLING OUTPUTS
- PARAMETER SECURITY VIA PROGRAMMABLE LOCKOUTS
- FIELD REPLACEABLE OUTPUT BOARD (Relay or Logic/SSR Drive)



- OPTIONAL TRIAC OUTPUT
- SECOND SETPOINT SETTING
- OPTIONAL REMOTE SETPOINT INPUT (0/4 to 20 mA)
- OPTIONAL RS-485 SERIAL COMMUNICATIONS
- PC SOFTWARE AVAILABLE FOR CONTROLLER CONFIGURATION



UL Recognized Component,
 File # E156876 (M)

DESCRIPTION

The T48 Controller accepts signals from a variety of temperature sensors (thermocouple or RTD elements), precisely displays the process temperature, and provides an accurate output control signal (*time proportional or linear DC*) to maintain the process at the desired temperature. The controller's comprehensive yet simple programming allows it to meet a wide variety of application requirements.

The controller operates in the PID control mode for both heating and cooling, with on-demand auto-tune, which will establish the tuning constants. The PID tuning constants may be fine-tuned by the operator at any time and then locked out from further modification. The controller employs a unique overshoot suppression feature, which allows the quickest response without excessive overshoot. The unit can be transferred to operate in the manual mode, providing the operator with direct control of the output. The controller may also be programmed to operate in the ON/OFF control mode with adjustable hysteresis.

A second setpoint is available on select models to allow quick selection of a different setpoint setting.

Dual 4-digit displays allow viewing of the process temperature and setpoint simultaneously. Front panel indicators inform the operator of the controller and output status. On many models the main control output and the alarm outputs are field replaceable.

Optional alarm(s) can be configured to activate according to a variety of actions (Absolute HI or LO, Deviation HI or LO, Band IN or OUT, and Heater Current Break) with adjustable hysteresis. A standby feature suppresses the alarm during power-up until the temperature stabilizes outside the alarm region. The second alarm can be configured as a secondary PID output (heat/cool applications).

Optional Main Linear DC output (10 V or 20 mA) can be used for control or temperature re-transmission purposes. Programmable output update time reduces valve or actuator activity. The output range can be scaled independent of the input range.

Optional Second Linear DC output (10 V or 20 mA) provides an independent temperature re-transmission, while the main Linear DC output is being used for control. The output range can be scaled independent of the input range.

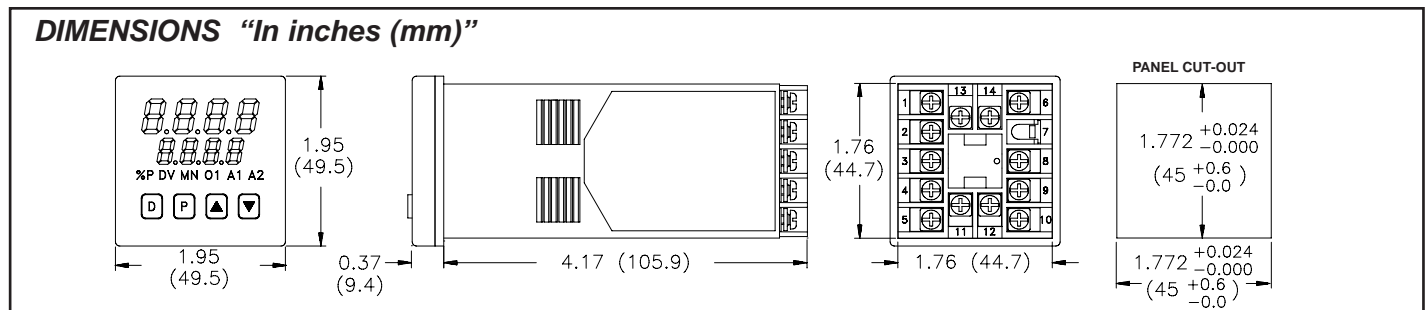
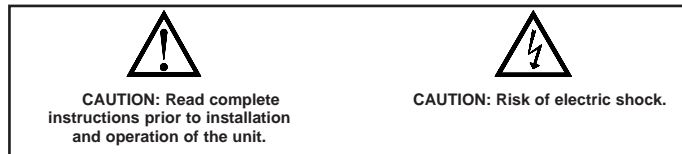

Optional Heater Current Monitor provides a direct readout of process heater current. An alarm can be programmed to signal when the heater has failed. This provides early warning of system failure before product quality is affected.

Optional Remote Setpoint input (0/4 to 20 mA) allows for multiple ganged controller operation for large oven and extruder applications; allows for cascade control loops, where tighter control is required; and allows for remotely driven setpoint signal from computers or other similar equipment. Straightforward end point scaling with independent filtering and local/remote transfer option expand the controller's flexibility.

The optional RS-485 serial communication interface provides two-way communication between a T48 and other compatible equipment such as a printer, PLC, HMI, or a host computer. In multipoint applications (up to thirty-two), the address number of each T48 on the line can be programmed from 0 to 99. Data from the T48 can be interrogated or changed, and alarm output(s) may be reset by sending the proper command code via serial communications. PC software, SFT48, allows for easy configuration of controller parameters. These settings can be saved to disk for later use or used for multi-controller down loading. On-line help is provided within the software.

The unit is constructed of a lightweight, high impact plastic case with a tinted front panel. The front panel meets NEMA 4X/IP65 specifications when properly installed. Multiple units can be stacked horizontally or vertically. Modern surface-mount technology, extensive testing, plus high immunity to noise interference makes the controller extremely reliable in industrial environments.

SAFETY SUMMARY

All safety related regulations, local codes and instructions that appear in the manual or on equipment must be observed to ensure personal safety and to prevent damage to either the instrument or equipment connected to it. If equipment is used in a manner not specified by the manufacturer, the protection provided by the equipment may be impaired.

Do not use the T48 to directly command motors, valves, or other actuators not equipped with safeguards. To do so can be potentially harmful to persons or equipment in the event of a fault to the controller. An independent and redundant temperature limit indicator with alarm outputs is strongly recommended.

SPECIFICATIONS

1. DISPLAY: Dual 4-digit

Upper Temperature Display: 0.4" (10.2 mm) high red LED

Lower Auxiliary Display: 0.3" (7.6 mm) high green LED

Display Messages:

- "OLOL" - Appears when measurement exceeds + sensor range.
- "ULUL" - Appears when measurement exceeds - sensor range.
- "OPEN" - Appears when open sensor is detected.
- "SHrt" - Appears when shorted sensor is detected (*RTD only*)
- "..." - Appears when display values exceed + display range.
- "-..." - Appears when display values exceed - display range.

LED Status Annunciators:

- %P - Lower auxiliary display shows power output in (%).
- MN - Flashing: Controller is in manual mode.
 - On: Local Setpoint (Remote Setpoint option)
 - Off: Remote Setpoint
- DV - Lower auxiliary display shows deviation (*error*) from temperature setpoint or shows heater current.
- O1 - Main control output is active.
- A1 - Alarm #1 is active (*for A1 option*).
- A2 - Alarm #2 is active OR
 - Cooling output (O2) is active

2. POWER:

AC Versions: 85 VAC min. to 250 VAC max., 50 to 60 Hz, 8 VA max.

DC Versions:

DC Power: 18 to 36 VDC; 7 W

AC Power: 24 VAC \pm 10%; 50 to 60 Hz, 9 VA

3. CONTROLS:

Four front panel push buttons for modification and setup of controller functions and one external input user for parameter lockout or other functions.

4. MEMORY:

Nonvolatile E² PROM retains all programmable parameters and values.

5. MAIN SENSOR INPUT:

Sample Period: 100 msec

Response Time: Less than 300 msec typ., 400 msec max. (*to within 99% of final value w/step input; typically, response is limited to response time of probe*)

Failed Sensor Response:

Main Control Output(s): Programmable preset output

Display: "OPEN"

Alarms: Upscale drive

Normal Mode Rejection: 40 dB @ 50/60 Hz (improves with increased digital filtering.)

Common Mode Rejection: Greater than 120 dB, DC to 60 Hz

Protection: Input overload 120 VAC max. for 15 seconds max.

6. THERMOCOUPLE INPUT:

Types: T, E, J, K, R, S, B, N, Linear mV, software selectable

Input Impedance: 20 M Ω all types

Lead resistance effect: 0.25 μ V/ Ω

Cold junction compensation: Less than $\pm 1^\circ\text{C}$ typ., ($\pm 1.5^\circ\text{C}$ max), error over 0 to 50 $^\circ\text{C}$ max. ambient temperature range. Defeated for Linear mV indication mode.

Resolution: 1 $^\circ$ for all types, or 0.1 $^\circ$ for T, E, J, K, and N only.

| TC TYPE | RANGE | WIRE COLOR | |
|---------|--|-------------|-------------|
| | | ANSI | BS 1843 |
| T | -200 to +400 $^\circ\text{C}$ -328 to +752 $^\circ\text{F}$ | blue (+) | white (+) |
| | | red (-) | blue (-) |
| E | -200 to +750 $^\circ\text{C}$ -328 to +1382 $^\circ\text{F}$ | violet (+) | brown (+) |
| | | red (-) | blue (-) |
| J | -200 to +760 $^\circ\text{C}$ -328 to 1400 $^\circ\text{F}$ | white (+) | yellow (+) |
| | | red (-) | blue (-) |
| K | -200 to +1250 $^\circ\text{C}$ -328 to +2282 $^\circ\text{F}$ | yellow (+) | brown (+) |
| | | red (-) | blue (-) |
| R | 0 to 1768 $^\circ\text{C}$ +32 to +3214 $^\circ\text{F}$ | black (+) | white (+) |
| | | red (-) | blue (-) |
| S | 0 to 1768 $^\circ\text{C}$ +32 to 3214 $^\circ\text{F}$ | black (+) | white (+) |
| | | red (-) | blue (-) |
| B | +149 to +1820 $^\circ\text{C}$ +300 to +3308 $^\circ\text{F}$ | grey (+) | no standard |
| | | red (-) | no standard |
| N | -200 to +1300 $^\circ\text{C}$ -328 to +2372 $^\circ\text{F}$ | orange (+) | orange (+) |
| | | red (-) | blue (-) |
| mV | -5.00 to +56.00 | no standard | no standard |

7. RTD INPUT: 2 or 3 wire, 100 Ω platinum, alpha = 0.00385 (DIN 43760), alpha = 0.0039162

Excitation: 150 μ A typical

Resolution: 1 or 0.1 degree

Lead Resistance: 15 Ω max. per input lead

| RTD TYPE | RANGE |
|----------|---|
| 385 | -200 to +600 $^\circ\text{C}$ -328 to +1100 $^\circ\text{F}$ |
| 392 | -200 to +600 $^\circ\text{C}$ -328 to +1100 $^\circ\text{F}$ |
| OHMS | 1.0 to 320.0 |

8. INDICATION ACCURACY: 0.3% of Span $\pm 1^\circ\text{C}$. (Includes NIST conformity, cold junction effect and A/D conversion errors at 23 $^\circ\text{C}$ after 20 min. warm-up.)

9. USER INPUT: Internally pulled up to +5 VDC (1 M Ω).

$V_{IN\ MAX} = 5.25\ \text{VDC}$, $V_{IL} = 0.85\ \text{V max.}$, $V_{IH} = 3.65\ \text{V min.}$,

$I_{OFF} = 1\ \mu\text{A max.}$

Response Time: 120 msec max.

Functions:

| | |
|------------------------------|------------------------------|
| Program Lock | Integral Action Lock |
| Auto/Manual Mode Select | Setpoint Ramp Enable |
| Reset Alarms | Setpoint 1/Setpoint 2 Select |
| Local/Remote Setpoint Select | Serial block point |

10. CONTROL AND ALARM OUTPUTS: (Heating, Cooling or Alarm)

Relay outputs with Form A contacts:

Contact Rating: 3 A @ 250 VAC or 30 VDC (resistive load)

1/10 HP @ 120 VAC (inductive load)

Life Expectancy: 100,000 cycles at max. load rating.

(Decreasing load and/or increasing cycle time, increases life expectancy.)

Logic/SSR Drive Outputs:

Rating: 45 mA @ 4 V min., 7 V nominal

Triac Outputs:

Type: Isolated, Zero Crossing Detection

Rating:

Voltage: 120/240 VAC

Max. Load Current: 1 Amp @ 35 $^\circ\text{C}$

0.75 Amp @ 50 $^\circ\text{C}$

Min Load Current: 10 mA

Offstate Leakage Current: 7 mA max. @ 60 Hz

Operating Frequency: 20 to 500 Hz

Protection: Internal transient snubber

11. MAIN CONTROL:

Control: PID or ON/OFF

Output: Time proportioning or Linear DC

Cycle time: Programmable

Auto-tune: When selected, sets proportional band, integral time, and derivative time values.

Probe Break Action: Programmable

12. **ALARMS:** 1 or 2 alarms (optional)

- Modes:** Absolute high acting
 Absolute low acting
 Deviation high acting
 Deviation low acting
 Inside band acting
 Outside band acting
 Heater break alarm

Reset Action: Programmable; automatic or latched

Standby Mode: Programmable; enable or disable

Hysteresis: Programmable

Probe Break Action: Upscale

Annunciator: LED backlight for "A1", "A2"

13. **COOLING:** Software selectable (overrides alarm 2)

Control: PID or ON/OFF

Output: Time Proportioning

Cycle time: Programmable

Proportional Gain Adjust: Programmable

Heat/Cool Deadband Overlap: Programmable

14. **MAIN AND SECOND LINEAR DC OUTPUT:** (optional)

Main: Control or Re-transmission, programmable update rate from 0.1 sec to 250 sec

Second: Re-transmission only, fixed update rate of 0.1 sec

| OUTPUT ** RANGE | ACCURACY * (18 to 28°C) | ACCURACY * (0 to 50°C) | COMPLIANCE | RESOLUTION |
|-----------------|-------------------------|------------------------|--------------|------------|
| 0 to 10 V | 0.10% of FS + 1/2 LSD | 0.30% of FS + 1/2 LSD | 10k ohm min. | 1/3500 |
| 0 to 20 mA | 0.10% of FS + 1/2 LSD | 0.30% of FS + 1/2 LSD | 500 ohm max. | 1/3500 |
| 4 to 20 mA | 0.10% of FS + 1/2 LSD | 0.30% of FS + 1/2 LSD | 500 ohm max. | 1/2800 |

* Accuracies are expressed as ± percentages after 20 minutes warm-up. Output accuracy is specified in two ways: Accuracy over an 18 to 28°C range at 10 to 75% RH environment; and accuracy over a 0 to 50°C range at 0 to 85% RH (non-condensing) environment. Accuracy over the wide temperature range reflects the temperature coefficient of the internal circuitry.

** Outputs are independently jumper selectable for either 10 V or 20 mA. The output range may be field calibrated to yield approximately 10% overrange and a small underrange (negative) signal.

15. **REMOTE SETPOINT INPUT:** (optional)

Input type:

0/4 to 20 mA

Input Resistance: 10 Ω

Overrange: -5% to 105%

Overload: 100 mA (continuous)

Scale Range: -999 to 9999 degrees or -99.9 to 999.9 degrees.

Resolution: 1 part in 10,000.

Accuracy:

At 25° C: ±(0.1 % of full scale + 1/2 LSD)

Over 0 to 50°C range: ±(0.2% of full scale + 1/2 LSD)

Reading Rate: 10/sec.

Setpoint Filtering: Programmable Digital

Setpoint Ramping: Programmable, 0.1 to 999.9 degrees/minute.

16. **HEATER CURRENT MONITOR INPUT:** (optional)

Type: Single phase, full wave monitoring of load currents controlled by main output (01).

Input: 100 mA AC output from current transformer (RLC #CT004001) or any CT with 100 mA AC output.

Display Scale Range: 1.0 to 999.9 Amps or 0.0 to 100.0%

Input Resistance: 5 Ω

Accuracy:

At 25° C: ±(0.5 % of full scale + 1/2 LSD), (5 to 100% of Range)

Over 0 to 50°C range: ±(1.0% of full scale + 1/2 LSD), (5 to 100% of Range)

Frequency: 50 to 400 Hz.

Alarm Mode: Dual acting; heater element fail detect and control device fail detect.

Overrange: 105% Capacity

Overload: 200 mA (continuous).

17. **SERIAL COMMUNICATIONS:** (optional)

Type: RS485 multipoint, balanced interface

Baud Rate: 300 to 9600

Data Format: 7 data bits, odd, even or no parity, 1 stop bit

Node Address: 0-99, max of 32 units per line

Transmit Delay: 2-100 msec or 100-200 msec

Data Encoding: ASCII

Isolation w.r.t Main Input Common: 500 Vrms for 1 min. (50 V working)
 Not isolated w.r.t. Remote Setpoint or Heater Current inputs, or Analog Output common

Note: RS485 and the Analog Output commons are not internally isolated within the controller. The terminating equipment of these outputs must not share the same common (ie. earth ground).

18. **ENVIRONMENTAL CONDITIONS:**

Operating Range: 0 to 50°C

Storage Range: -40 to 80°C

Span Drift (max.): 130 ppm/°C, main input

Zero Drift (max.): 1µV/°C, main input

Operating and Storage Humidity:

85% max. relative humidity (non-condensing) from 0°C to 50°C.

Altitude: Up to 2000 meters

19. **ISOLATION BREAKDOWN RATINGS:**

AC line with respect to all inputs and outputs: 2000 Volts

Main input with respect to Analog Output, Remote Setpoint Input, Heater Current Input: 500 Volts for 60 sec min.

All other inputs and outputs with respect to relay contacts: 2000 VAC

20. **CERTIFICATIONS AND COMPLIANCES:**

UL Recognized Component: File #E156876 (M)

Recognized to U.S. and Canadian requirements under the Component Recognition Program of Underwriters Laboratories, Inc.

ELECTROMAGNETIC COMPATIBILITY

Immunity to EN 50082-2

| | | |
|-----------------------------------|--------------|--|
| Electrostatic discharge | EN 61000-4-2 | Level 2; 4 Kv contact Level 3; 8 Kv air |
| Electromagnetic RF fields | EN 61000-4-3 | Level 3; 10 V/m ¹ 80 MHz - 1 GHz |
| Fast transients (burst) | EN 61000-4-4 | Level 4; 2 Kv I/O Level 3; 2 Kv power |
| RF conducted interference | EN 61000-4-6 | Level 3; 10 V/rms ² 150 KHz - 80 MHz |
| Simulation of cordless telephones | ENV50204 | Level 3; 10 V/m 900 MHz ± 5 MHz 200 Hz, 50% duty cycle |

Emissions to EN 50081-2

| | | |
|-----------------|----------|--|
| RF interference | EN 55011 | Enclosure class A Power mains class A |
|-----------------|----------|--|

Notes:

1. No loss of performance during EMI disturbance at 10 V/m.

Unit is panel mounted in a metal enclosure (Buckeye SM7013-0 or equivalent) that provides at least 20 dB shielding effectiveness. Metal panel is connected to earth ground.

I/O cables routed in metal conduit connected to earth ground.

Install power line filter, RLC #LFIL0000 or equivalent.

2. Permissible loss of performance during EMI disturbance at 10 Vrms:

Process signal deviation less than 3% of full scale.

Analog output deviation less than 1% of full scale.

RSP and HCM signal deviation less than 0.5% of full scale.

For operation without loss of performance:

Install power line filter, RLC #LFIL0000 or equivalent.

OR

Install 2 ferrite cores, RLC #FCOR0000 or equivalent, to AC lines at unit for frequencies above 5 MHz.

I/O cables routed in metal conduit connected to earth ground.

Refer to the EMC Installation Guidelines section of the manual for additional information.

21. **CONNECTION:** Wire clamping screw terminals

22. **CONSTRUCTION:** Black plastic alloy case and collar style panel latch. Panel latch can be installed for vertical or horizontal instrument stacking. One piece tinted plastic bezel. Bezel assembly with circuit boards can be removed from the case to change the output board without removing the case from the panel or disconnecting wiring. Unit meets NEMA 4X/IP65 requirements for indoor use, when properly installed. Installation Category II, Pollution Degree 2.

23. **WEIGHT:** 0.38 lbs (0.17 kgs)

BASIC OPERATION

The T48 controls a process temperature by measuring the temperature via an input probe, then calculating a control output power value by use of a modified PID control algorithm. The unit controls the system with the new output power value to keep the process temperature at setpoint. The PID control algorithm incorporates features which provide for high control accuracy and low temperature overshoot from process disturbances.

FRONT PANEL FEATURES

In the normal operating mode, the unit displays the process temperature in the upper display. One of the following parameters can be viewed in the lower display:

- Setpoint
- % Power Output
- Temperature Deviation
- Heater Current
- Temperature symbol (F or C)
- Blank Display

The user scrolls through these parameters by pressing the D button. If enabled, the control setpoint or power output (manual mode only) can be directly modified in this mode.

In the normal operating mode, parameters are selected by use of the P button and modified by use of the UP and DOWN buttons. Parameters are then entered by the P button, which advances the user to the next parameter. Pressing the D button immediately returns the controller to the normal operating mode without changing the currently selected parameter.

HARDWARE FEATURES

A fast 100 msec input sampling rate provides quick controller response to a process disturbance, thus providing excellent temperature control. Measurement accuracy of 0.3% of span $\pm 1^{\circ}\text{C}$ or better, provides close process control conforming to the desired control setpoint value. The T48 accepts a variety of both thermocouple and RTD temperature probes. An output board contains the Main Control output, Alarm 1 output, Alarm 2/Cooling output, and/or Linear DC output. Since the controller is serviceable from the front of the panel, the output board (on some models) may be easily changed or replaced without disturbing the wiring behind the panel. No re-programming is required when changing or replacing the output board for units without the Linear DC output option. Units with the linear output option require calibration procedure for the new linear output.

Low-drift, highly stable circuitry ensures years of reliable and accurate temperature control. The recommended two year re-calibration interval is easily accomplished via the programming menu.

REMOTE SETPOINT INPUT

The remote setpoint input facilitates the use of a remote signal to drive the controller's setpoint. The remote signal can be scaled independent to that of the controller's range. The controller's response to local/remote setpoint transfers can be programmed. Also, the remote signal is filtered by use of an adaptive filter. With this filter, relatively large filtering time constants can be used without suffering from long settling times. The time constant and filter disable band are programmable. Additionally, the remote signal can also be velocity limited (or ramped) to slow the controller's response to changes in setpoint. This results in a steady control response with no overshoot.

HEATER CURRENT MONITOR

The T48 provides a direct readout of process heater current. This provides valuable information regarding single phase heater system integrity. It is especially useful on extruder and large oven applications where adjacent controllers mask the effect of a failed heater. The heater break alarm senses two types of heater system faults:

- 1) Main control output is "on" and heater current is below alarm value. This indicates failed heater or failed parts of heater, breaker trip, failed power control device, etc.
- 2) Main control output is "off" and heater current is above 10% of alarm value. This indicates a failed power control device, wiring fault, etc.

LINEAR DC ANALOG OUTPUTS

The Main Linear DC output has independent scaling, programmable output update time and filter (damping) time. These parameters permit flexibility in process configuration. The output can be set for 0 to 10V, 0 to 20 mA or 4 to 20 mA ranges, and can be configured for control or for transmission of temperature or setpoint values.

A Second Linear DC output is dedicated for retransmission of input temperature. The output can be scaled and converted independent of the input and Main Linear DC output. This output is isolated from the input.

SETPOINT FEATURES

The controller setpoint can be protected from out of range values by programming the setpoint range limit values. Additionally, safeguards from inadvertent data entry can be programmed.

A second setpoint value can be programmed which can be made active by a user input and/or through the front panel on selected models.

The setpoint ramp feature ramps the setpoint value at start-up or any time a setpoint change is made, at a user programmable rate. This feature reduces thermal shock to the process and helps to minimize temperature overshoot.

INPUT FEATURES

A programmable input filter can be used to stabilize readings from a process with varying or oscillating temperature characteristics, helping to provide better temperature control. A programmable temperature shift function can be used to compensate for probe errors or to have multiple T48 units indicate the same nominal temperature.

The programmable User Input can be used to control a variety of functions, such as auto/manual transfer of the controller, reset alarm output(s), transfer to second setpoint, etc.

OUTPUT FEATURES

Programmable output power limits provide protection for processes where excessive power can cause damage. Automatic sensor probe break detection, for fail-safe operation, causes the controller to default to a programmed output power (upscale or downscale burnout). Programmable output cycle time, output hysteresis and dampening can reduce output activity without degrading control accuracy. The main outputs can operate in PID, ON/OFF, or manual control modes.

CONTROL AND ALARM OUTPUTS

In addition to the Linear DC outputs, there are up to three types of ON/OFF outputs. These outputs can be relay, logic, or triac for control or alarm purposes. Relay outputs can switch user applied AC or DC voltages. Logic/SSR drive outputs supply power to external SSR power units, that can switch up to 45 Amps. One Logic/SSR Drive output can control up to four SSR power units at one time. The Triac output supplies one Amp of AC current for control of an external AC relay or triac device.

AUTO-TUNE

The T48 has an auto-tune feature which, on demand, automatically determines the PID control parameters for a particular thermal process. After completion of auto-tune, the PID parameters are automatically optimized for that process and loaded into non-volatile memory. The operator may view and modify the parameters as desired.

Auto-tune may be invoked either at start-up or at setpoint, depending on the process requirements. An auto-tune programmable dampening factor produces various levels of process control and response characteristics.

RS-485 Communications

The RS-485 communications option allows the connection of up to 32 devices on a single pair of wires with a distance of up to 4,000 feet and a maximum baud rate of 9600. Since the same pair of wires are used for both transmit and receive, only one way communication is possible at any given time. The controller has a programmable response time to allow the host device adequate time to release the communication line for a transmission.

Selected parameters from the T48 can be interrogated or changed, and alarm output(s) may be reset by sending the proper command code via serial communications. It is also possible to invoke Auto-tune through the serial port. Serial communications used with SFT48 software allows for easy controller parameter configuration by computer.

HEATING AND COOLING SYSTEMS

The T48 is available with dual outputs to provide heating and cooling to those processes that require them. For example, many extruder applications require both heating and cooling to maintain accurate extruder barrel and die temperatures. The T48 is easily configured for these types of applications.

CONTROLLER PROGRAMMING

Front Panel Program Disable allows all of the controller's set-ups to be locked-out from further operator intervention after the initial set-up.

The following four programming modes allow the controller to adapt to any required user-interface level:

- Unprotected Parameter Mode
- Protected Parameter Mode
- Hidden Function Mode
- Configuration Parameter Mode

UNPROTECTED PARAMETERS MODE *

The Unprotected Parameters Mode is accessible from the Normal Display Mode when program disable is inactive or when the proper access code number from the Protected Parameter Mode is entered. The Configuration Parameter Modes can be accessed only from this mode.

- "SP" - Enter setpoint
- "OP" - Enter output power
- "ProP" - Enter proportional band
- "Intt" - Enter integral time
- "dErt" - Enter derivative time
- "AL-1" - Enter value for alarm #1
- "AL-2" - Enter value for alarm #2
- "CNFP" - Select configuration access point
- "End" - Return to normal display mode

PROTECTED PARAMETERS MODE *

The Protected Parameters Mode is enabled when program disable is active. This mode prevents access to the Configuration Parameter Modes without the proper access code number. Only the parameters that are enabled in the Configuration 3 parameter (lock-out section) can be accessed.

- "ProP" - Enter proportional band
- "Intt" - Enter integral time
- "dErt" - Enter derivative time
- "AL-1" - Enter value for alarm #1
- "AL-2" - Enter value for alarm #2
- "CodE" - Enter value to access unprotected parameters and configuration parameters

HIDDEN FUNCTION MODE *

The Hidden Function Mode is accessible from the Normal Display Mode. The functions in this mode may be locked-out individually in Configuration 3 parameter (lock-out section).

- "SPSL" - Select local (SP1 or SP2) or remote setpoint
- "trnF" - Transfer between automatic (PID) control and manual control
- "tUNE" - Invoke/cancel PID Auto-tune
- "ALrS" - Reset latched alarms

CONFIGURATION PARAMETER MODE

The Configuration Parameter Mode allows the operator to set-up the basic requirements of the controller. It is divided into sections which group together related programming steps, such as inputs, outputs, alarms, etc. Upon completion of each section, the program returns to the Configuration Access Point, allowing the user to return to the Normal Display Mode.

Configuration 1, Inputs (1-IN)

- "TYPE" - Select input probe type
- "SCAL" - Select temperature scale
- "dCP" - Select temperature resolution
- "FLtr" - Select level of input filtering
- "SHFt" - Enter input correction shift (offset)
- "SPLO" - Enter setpoint lower limit
- "SPHI" - Enter setpoint higher limit
- "SPrP" - Enter setpoint ramp rate
- "InPt" - Select user input function

Configuration 2, Outputs (2-OP) *

- "CYCt" - Enter time proportioning cycle time
- "OPAC" - Select output control action
- "OPLO" - Enter output power low limit
- "OPHI" - Enter output power high limit
- "OPFL" - Enter probe fail power preset
- "OPdP" - Enter output control dampening
- "CHYS" - Enter ON/OFF control hysteresis
- "tcod" - Select auto-tuning dampening
- "AntP" - Main Linear DC analog output range
- "ANAS" - Main Linear DC analog output source
- "ANut" - Main Linear DC analog output update time
- "ANLO" - Main Linear DC analog output scaling low
- "ANHI" - Main Linear DC analog output scaling high

Configuration 3, Parameter Lock-Outs (3-LC) *

- "SP" - Select setpoint access level
- "OP" - Select power access level
- "dEv" - Enable deviation display
- "Hcur" - Enable heater current display
- "UdSP" - Enable temperature scale display
- "CodE" - Enter parameter access code
- "Pid" - Select PID access level
- "AL" - Select alarm access level
- "ALrS" - Enable alarm reset access
- "SPSL" - Enable local/remote selection
- "trnF" - Enable auto/manual mode selection
- "tUNE" - Enable auto-tune invocation

Configuration 4, Alarms (4-AL) *

- "Act1" - Select operation mode of alarm #1, or select heat output
- "rSt1" - Select reset mode of alarm #1
- "Stb1" - Enable activation delay of alarm #1
- "AL-1" - Enter value for alarm #1
- "Act2" - Select operation mode of alarm #2, or select cooling output
- "rSt2" - Select reset mode of alarm #2
- "Stb2" - Enable activation delay of alarm #2
- "AL-2" - Enter value for alarm #2
- "AHYS" - Enter hysteresis value for both alarms

Configuration 5, Cooling (5-O2) *

- "CYC2" - Enter cooling time proportioning cycle time
- "GAN2" - Enter cooling relative gain
- "db-2" - Enter heat/cool deadband or overlap

Configuration 6, Serial Communications (6-SC) *

- "bAUd" - Select baud rate
- "PARb" - Select parity bit
- "Add" - Enter address
- "Abr" - Select abbreviated or full transmission
- "PoPt" - Select print options

Configuration 7, Remote Setpoint Input (7-N2) *

- "dSP1" - Enter remote setpoint display scaling value #1
- "INP1" - Enter remote setpoint process scaling value #1
- "dSP2" - Enter remote setpoint display scaling value #2
- "INP2" - Enter remote setpoint process scaling value #2
- "FLtr" - Enter remote setpoint filter time constant
- "bAnd" - Enter remote setpoint filter disable band
- "trnF" - Select Local/Remote setpoint transfer response

Configuration 7 - Heater Current Parameters (7-N2) *

- "Hcur" - Enter full scale rating of CT

Configuration 8, Second Linear DC Analog Output (8-A2) *

- "A2tP" - Second linear DC analog range
- "A2LO" - Second linear DC analog scaling low
- "A2HI" - Second linear DC analog scaling high

Configuration 9, Factory Service Operations (9-FS)

- "Code 48" - Calibrate Instrument
- "Code 66" - Reset parameters to factory setting

* These parameters may not appear due to option configuration or other programming.

MULTIPLE UNIT STACKING

The T48 is designed for close spacing of multiple units. Units can be stacked either horizontally or vertically. For vertical stacking, install the panel latch with the screws to the sides of the unit. For horizontal stacking, the panel latch screws should be at the top and bottom of the unit. The minimum spacing from center line to center line of units is 1.96" (49.8 mm). This spacing is the same for vertical or horizontal stacking.

Note: When stacking units, provide adequate panel ventilation to ensure that the maximum operating temperature range is not exceeded.

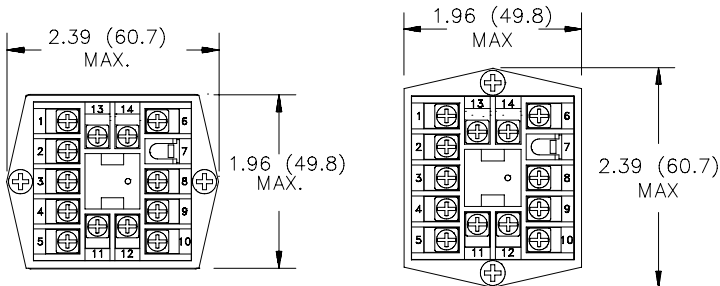

PANEL LATCH INSTALLED FOR VERTICAL UNIT STACKING

PANEL LATCH INSTALLED FOR HORIZONTAL UNIT STACKING

PANEL CUT-OUT SPACING FOR MULTIPLE UNIT STACKING. HORIZONTAL ARRANGEMENT SHOWN.

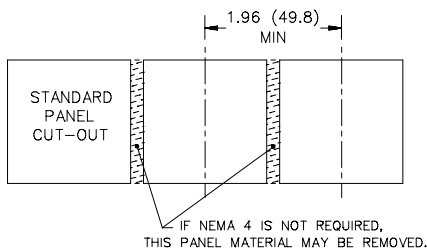

ACCESSORY - CURRENT TRANSFORMER-50A

The external Current Transformer is used when specifying the T48's equipped with the Heater Current Monitor.

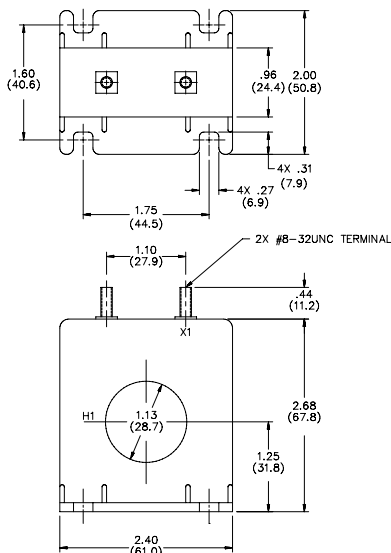

Part Number: CT005001

Current Ratio: 50 : 0.1 (Amperes)

Operation Frequency: 50 to 400 Hz

Insulation Class: 0.6 KV BIL, 10 KV full wave.VA 60 H2 Burden 2.5

Terminals: Brass studs No. 8-32 UNC with one flat washer, lockwasher, and hex nut.

Window Diameter: 1.13" (28.7 mm)

Weight: 8 oz (226.0g)

ACCESSORY - EXTERNAL SSR POWER UNIT

The external SSR Power Unit is used with T48's equipped with Logic/SSR Drive outputs to switch loads up to 240 VAC @ 45 Amps, 25°C ambient. The unit is operated by applying a low level DC control signal to the isolated input. The unit features zero cross detection circuits which reduces radiated RFI when switching load currents. With no contacts to wear out, the SSR Power Unit provides virtually limitless operational life. The unit is supplied with an integral heat sink for immediate installation.

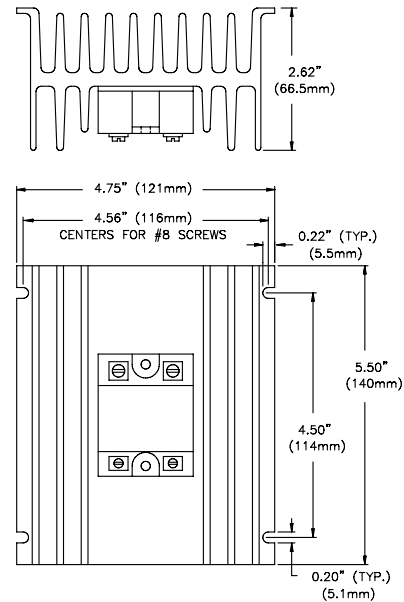

External SSR Power Unit:

Part Number: RLY50000

Switched Voltage Range: 50 to 280 VAC

Load Current: 45 Amps max. @ 25°C ambient temperature

35 Amps max. @ 50°C ambient temperature

On State Input: 3 to 32 VDC @ 1500 Ω impedance. (isolated)

(Use Logic/SSR drive output .)

Off State Input: 0.0 to 1.0 VDC

Size: 5.5" (14 cm) L x 4.75" (12 cm) W x 2.62" (6.6 cm) H

ACCESSORY - CURRENT TRANSFORMER-40A

The external Current Transformer is used when specifying the T48's equipped with the Heater Current Monitor.

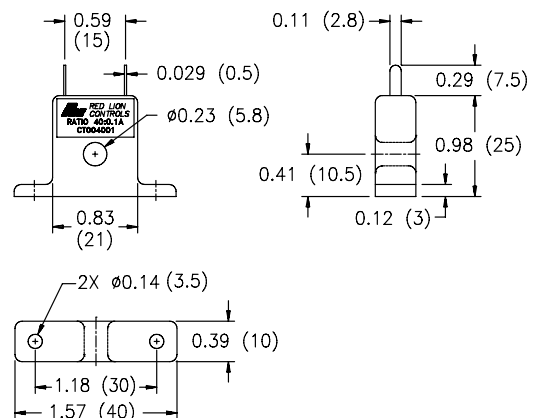

Current Transformers:

Part Number: CT004001

Current Ratio: 40 : 0.1 (Amperes)

Max Heater Current: 50 A

Dielectric Strength: 1000 VAC (For 1 minute)

Vibration Resistance: 50 Hz (Approx 10 G)

Terminals: Solder Type

Window Diameter: 0.228" (5.8 mm)

Weight: 0.406 oz (11.5 g)

APPLICATION

PLASTICS EXTRUDER APPLICATION

Several T48 controllers are employed to control the temperature of a plastics extruder. Each T48 controls a heating element and a cooling water solenoid to maintain each extruder zone at the desired temperature. The Heater Current Monitor option is used to provide a readout of the heater current. The multi-function User Input can be programmed to allow selection of manual operation when connected to common. This allows the user to hold the control output of the controller during abnormal process conditions.

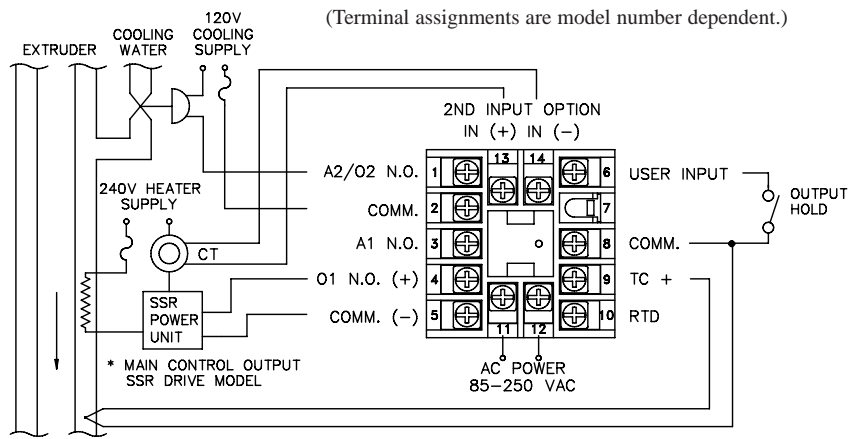

OEM PAINT SPRAYER APPLICATION

An OEM manufacturing spray painting equipment utilizes the T48 to maintain optimum paint temperature. In addition to the low cost, the 1/16 DIN package size permits the OEM to design "time proportioning" control into various sized painting equipment, from small hand sprayers to large paint booths. The heating element used to heat the paint is connected to the Main Control Output (OP1). Alarm 1 is programmed as Band Inside Acting, so that as long as the paint temperature is within manufacturer's specifications for temperature, the "GO" light is on. Alarm 2 is programmed as Band Outside Acting so that the "NO GO" light is on when the paint temperature is outside the manufacturer's specifications.

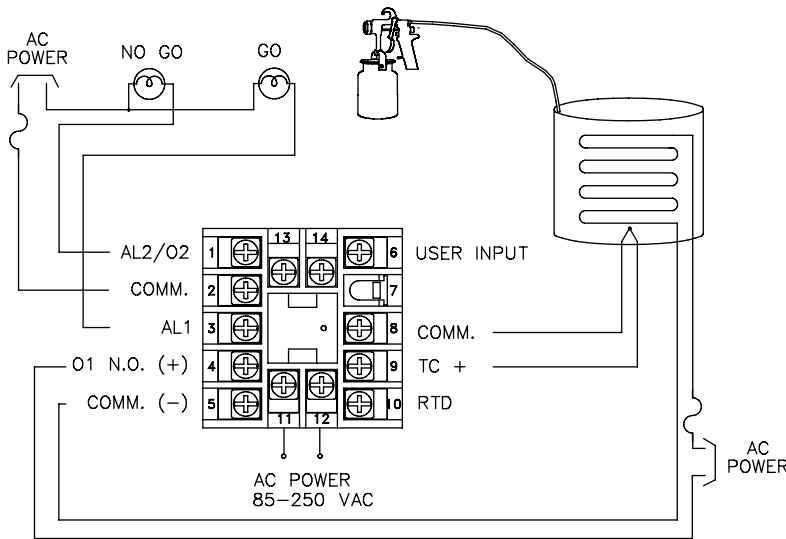

MULTIPLE UNIT/REMOTE SETPOINT APPLICATION

Eight T48 controllers are used in a drying oven. Each T48 controls a zone within the oven. Depending upon the material to be dried, and its initial moisture content, the drying setpoint temperature varies. A master T48 controller transmits setpoint via linear DC output. This signal is received as a remote setpoint signal by the other slave controllers.

Whenever the master controller's setpoint is changed, the slave controller's setpoint changes automatically.

The remote setpoint input at each slave controller can be scaled independently.

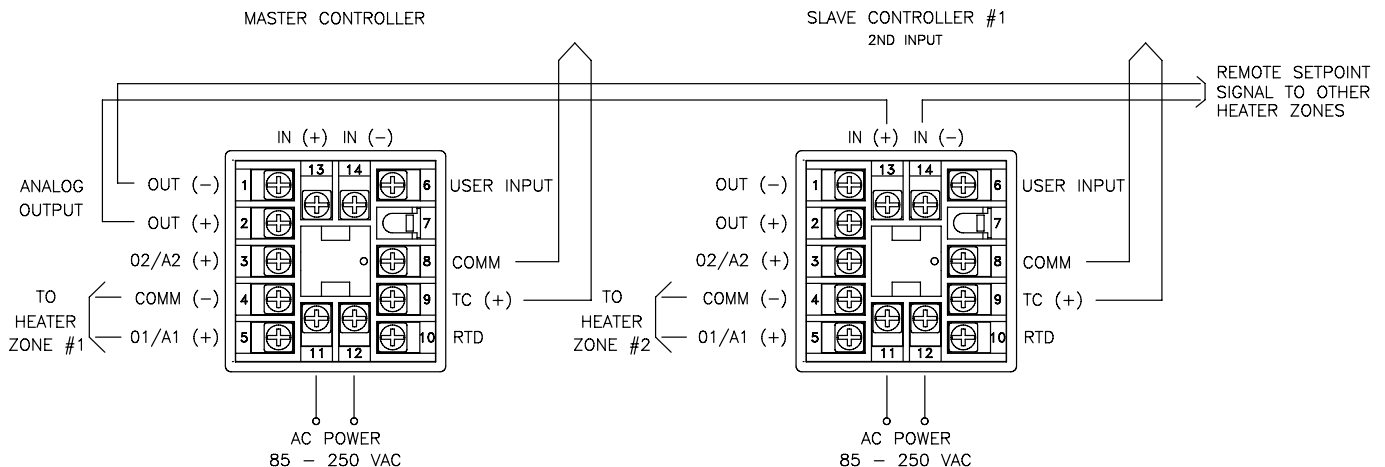

ORDERING INFORMATION

Options and Output Boards are factory configured per the part number specified. Part numbers without replacement output boards listed must be returned to the factory for output board replacement.

MODELS WITHOUT RS-485 AND LINEAR DC ANALOG OUTPUT

| DEDICATED MAIN CONTROL O1 OUTPUT | DEDICATED ALARM 1 A1 OUTPUT | (ALARM 2) A2 OR O2 (COOL)* | REMOTE SETPOINT INPUT | HEATER CURRENT INPUT@ | REPLACEMENT OUTPUT BOARD | PART NUMBERS | |
|----------------------------------|-----------------------------|----------------------------|-----------------------|-----------------------|--------------------------|------------------|---------------|
| | | | | | | 18-36 VDC/24 VAC | 85 TO 250 VAC |
| Relay | | | | | RBD48100 | T4810010 | T4810000 |
| Relay | Relay | | | | RBD48111 | NA | T4811000 |
| Relay | Relay | Relay | | | RBD48111 | T4811110 | T4811100 |
| Relay | Relay | Relay | YES | | RBD48111 | T4811113 | T4811103 |
| Relay | Relay | Relay | | YES | RBD48111 | T4811114 | T4811104 |
| Logic/SSR | | | | | RBD48200 | T4820010 | T4820000 |
| Logic/SSR | Relay | | | | RBD48211 | NA | T4821000 |
| Logic/SSR | Relay | Relay | | | RBD48211 | T4821110 | T4821100 |
| Logic/SSR | Relay | Relay | YES | | RBD48211 | T4821113 | T4821103 |
| Logic/SSR | Relay | Relay | | YES | RBD48211 | T4821114 | T4821104 |
| Triac | Logic/SSR | Logic/SSR | | | NA | T4832210 | T4832200 |

* - These part numbers have a single output, programmable as either Control (PID) or as an Alarm.

@ - These part numbers are software V4.0 or greater, and are equipped with a second setpoint.

Option Boards are installed at the factory for the appropriate models. These boards are only needed for field replacement.

MODELS WITH RS-485 OR LINEAR DC ANALOG OUTPUT

| DEDICATED MAIN CONTROL O1 OUTPUT | MAIN CONTROL O1 OR A1 (ALARM 1) * | DEDICATED ALARM 1 A1 OUTPUT | (ALARM 2) A2 OR O2 (COOL) * | REMOTE SETPOINT INPUT @ | HEATER CURRENT INPUT @ | RS485 @ | MAIN ANALOG OUTPUT** @ | SECOND ANALOG OUTPUT** @ | PART NUMBERS | |
|----------------------------------|-----------------------------------|-----------------------------|-----------------------------|-------------------------|------------------------|------------------|------------------------|--------------------------|------------------|---------------|
| | | | | | | | | | 18-36 VDC/24 VAC | 85 TO 250 VAC |
| Relay | | | | | | YES ¹ | | | NA | T4810002 |
| | Relay | | Relay | | | | YES | YES | T481011A | T481010A |
| | Relay | | Relay | | | | YES | | T4810111 | T4810101 |
| | Relay | | Relay | YES | | | YES | | T4810115 | T4810105 |
| | Relay | | Relay | | YES | | YES | | T4810116 | T4810106 |
| | Relay | | Relay | | | YES | YES | | T4810117 | T4810107 |
| Relay | | | Relay | YES | | YES | | | T4810118 | T4810108 |
| Relay | | | Relay | | YES | YES | | | T4810119 | T4810109 |
| Relay | | Relay | Relay | | | YES ² | | | T4811112 | T4811102 |
| | Logic/SSR | | Logic/SSR | | | | YES | | T4820211 | T4820201 |
| | Logic/SSR | | Logic/SSR | YES | | | YES | | T4820215 | T4820205 |
| | Logic/SSR | | Logic/SSR | | YES | | YES | | T4820216 | T4820206 |
| Logic/SSR | | | Logic/SSR | YES | | YES | | | T4820218 | T4820208 |
| Logic/SSR | | | Logic/SSR | | YES | YES | | | T4820219 | T4820209 |
| Logic/SSR | | Relay | Relay | | | YES | | | T4821112 | T4821102 |

* - These part numbers have a single output, programmable as either Control (PID) or as an Alarm.

** - These part numbers are jumper and program selectable for either a current or voltage Linear DC output.

@ - These part numbers are software V4.0 or greater, and are equipped with a second setpoint.

1 - Replacement Output Board RBD48100 may be used.

2 - Replacement Output Board RBD48111 may be used.

ACCESSORIES

| MODEL | DESCRIPTION | PART NUMBERS |
|-------|--|--------------|
| RLY | External SSR Power Unit (for Logic/SSR output models) | RLY50000 |
| CT | 40 Ampere Current Transformer (for Heater Current Input models) | CT004001 |
| CT | 50 Ampere Current Transformer (for Heater Current Input models) | CT005001 |
| SFT48 | PC Configuration Software for Windows 3.x and 95 (3.5" disk) (for RS-485 models) | SFT48 |

Red Lion Controls
20 Willow Springs Circle
York PA 17402
Tel +1 (717) 767-6511
Fax +1 (717) 764-6587

Red Lion Controls France
56 Boulevard du Courcerin, Batiment 21,
ZI Pariest F-77183 Croissy Beaubourg
Tel +33 (64) 80 12 12
Fax +33 (64) 80 12 13

Red Lion UK Ltd
Tapton Park
Chesterfield S41 0TZ
Tel +44 (1246) 22 21 22
Fax +44 (1246) 22 12 22